



TRUCUT™ OPERATING MANUAL



ENGLISH



WELDING IN AMERICA.
SINCE THE BEGINNING.



ITEM# 357
REV 10.22.2025



FOUR WAYS TO ORDER

Web: www.forneyind.com

Phone: 800-521-6038

Fax: 970-498-9505

Mail: Forney Industries
2057 Vermont Drive
Fort Collins, CO 80525

U.S. Facilities:

- Fort Collins, CO
- Vandalia, OH



The Forney Promise

At Forney Industries, we are unwavering in our commitment to your success, no matter your location, size or needs.

A Message from Our President & CEO

Thank you for choosing a Forney product.

Since 1932, Forney has been at the forefront of innovation and excellence in all facets of our business. J.D. Forney was an entrepreneur who invented the instant-heat soldering iron and the first 110-volt Arc Welder. For over 90 years, we have continued this legacy, introducing our latest welding machines, plasma cutters and several new metal working products for the retail and industrial sectors.

When you choose Forney, you are investing in reliability, dependability, and quality, backed by a dedicated team:

- Our Expert-Tech™ team of engineers and technicians are just a phone call away anytime you need help with a Forney machine or have questions about our products and accessories.
- The Forney Customer Service team is staffed Monday through Friday from 7am – 5pm Mountain Time to address any questions regarding products, services, or account maintenance.
- Our Product Development and Marketing Teams communicate new, innovative products on a regular basis. Learn about our newest product innovations by signing up for our emails at www.Forneyind.com.

At Forney, we are dedicated to surpassing your expectations. Because, when our customers succeed, we succeed.

Steven G. Anderson

STEVEN G. ANDERSON, President & CEO
FORNEY INDUSTRIES, INC.

Copyright© 2025 Forney Industries, Inc. All rights reserved. Unauthorized reproduction and/or distribution is subject to US copyright laws.



TECHNICAL ISSUES? FORNEY CAN HELP!

Thank you for choosing Forney! Please note: The store you purchased this machine from DOES NOT handle product returns. Forney Industries will repair or replace defective products at no charge to you that are under warranty!

When you call Forney's Technical Service department, you will speak to a trained product and application expert. Forney's primary goal is to get your machine up and running in as little time as possible. In fact, the majority of issues can be fixed over the phone! Please be near your machine when you call, so the Forney technician can guide you.

Speaking to a Forney Technician directly helps us gather better data, and improve our products. It is our highest priority to ensure our customers are cared for.



WE MAKE IT EASY!

Please contact Forney Industries Technical Service at 800-521-6038 Ext. 2 or customerservice@forneyind.com for inquiries, technical and general questions.

Table of Contents





































THE FORNEY PROMISE.....	2
EXPERT-TECH™ INFORMATION	3
TABLE OF CONTENTS	4
READ MANUAL	5
SAFETY SUMMARY	5
SYMBOLS LEGEND	5
PRINCIPAL SAFETY STANDARDS.....	6
CALIFORNIA PROPOSITION 65 WARNING	6
ELECTROMAGNETIC FIELD INFORMATION.....	6
PERSONAL PROTECTION.....	7
FIRE PREVENTION	8
HIGH-FREQUENCY RADIATION	9
ELECTRIC SHOCK	9
NOISE	10
ADDITIONAL SAFETY INFORMATION.....	10
BOX CONTENTS	11
INSTALLATION	12
MACHINE SPECIFICATIONS.....	12
SITE SELECTION	12
CONNECT INPUT POWER.....	13
GROUNDING REQUIREMENTS	13
USING POWER ADAPTERS	13
GENERATORS	13
VENTILATION.....	13
ADDITIONAL WARNINGS	13
GETTING TO KNOW YOUR MACHINE	15
DESCRIPTION.....	15
MACHINE LAYOUT AND CONTROLS	15
PLASMA	
COMPRESSED GAS SUPPLY	18
CHECKING AIR SUPPLY QUALITY	18
TORCH CONSUMABLE PARTS.....	19
OPERATION.....	21
PERFORMANCE DATA PLATE & DUTY-CYCLE	21
INTERNAL THERMAL PROTECTION.....	22
WELDING AND CUTTING PREPARATION	22
GROUND CLAMP ATTACHMENT.....	22
PLASMA	
SET UP	23
CUTTING	23
CUTTING CAPACITY	24
MAINTENANCE & SERVICING	25
GENERAL MAINTENANCE	25
PLASMA	
CONSUMABLE CARE	26
CONSUMABLE MAINTENANCE.....	26
TROUBLESHOOTING.....	28
MACHINE PARTS DIAGRAM & CONSUMABLES DIAGRAM	32

CAUTION!

BEFORE INSTALLING, OPERATING OR CARRYING OUT MAINTENANCE ON THE MACHINE, READ THE CONTENTS OF THIS MANUAL CAREFULLY, PAYING PARTICULAR ATTENTION TO THE SAFETY RULES AND HAZARDS.

In the event of these instructions not being clear, please contact your Forney Authorized Dealer or Forney Customer Service 1-800-521-6038.

Symbols Legend

SYMBOL	MEANING	SYMBOL	MEANING	SYMBOL	MEANING
	ARC RAYS HAZARD		FIRE HAZARD		NOISE HAZARD
	POISON HAZARD		ELECTRICAL HAZARD		WARNING/CAUTION
	BURN HAZARD		ELECTROMAGNETIC INTERFERENCE		EXPLOSION HAZARD
	FALLING EQUIPMENT HAZARD		FUMES, VAPORS, GASSES HAZARD		HF RADIATION INTERFERENCE
	MAGNETIC FIELD HAZARD		MOVING PARTS HAZARD		OVERHEATING HAZARD
	PERSONAL PROTECTIVE EQUIPMENT NEEDED		PLASMA ARC CUTTING		PLASMA CUTTING TORCH TRIGGERED
	PULSE (% ON)		MIG (GMAW)		INPUT VOLTAGE
	STICK (SMAW)		TEMPERATURE		LINE CONNECTION
	TIG (GTAW)		VOLTAGE		SINGLE PHASE ALTERNATING CURRENT (AC)
	POSITIVE DINSE		AMPERAGE		DIRECT CURRENT (DC)
	NEGATIVE DINSE		Wire-Feed		SUITABLE FOR USE IN AN ENVIRONMENT WITH INCREASED RISK OF ELECTRIC SHOCK
	MATERIAL THICKNESS		ON		OFF

Safety Summary

The data within this safety summary are highlights of various safety standards. It is recommended that you familiarize yourself with the standards listed below before use.

Principal Safety Standards

- ANSI Z49.1: SAFETY IN WELDING AND CUTTING - Obtainable from the American Welding Society, 550 NW Le Jeune Road, Miami, FL 33126 Telephone (800) 443-9353, Fax (305) 443-7559 - www.aws.org.
- OSHA 29 CFR, Part 1910, Subpart Q.: WELDING, CUTTING AND BRAZING - Obtainable from your state OSHA office or U.S. Dept. of Labor OSHA, Office of Public Affairs, Room N3647, 200 Constitution Ave., Washington, DC 20210 - www.osha.gov.
- AWS F4.1: SAFE PRACTICES FOR THE PREPARATION FOR WELDING AND CUTTING OF CONTAINERS AND PIPING FOR WELDING AND CUTTING. - Obtainable from the American Welding Society, 550 NW Le Jeune Road, Miami, FL 33126 Telephone (800) 443-9353, Fax (305) 443-7559 - www.aws.org.
- AWS A6.0. WELDING AND CUTTING CONTAINERS WHICH HAVE HELD COMBUSTIBLES - Obtainable from the American Welding Society, 550 NW Le Jeune Road, Miami, FL 33126 Telephone (800) 443-9353, Fax (305) 443-7559 - www.aws.org.
- NFPA 70: NATIONAL ELECTRICAL CODE - Obtainable from the National Fire Protection Association, 1 Batterymarch Park, P.O. Box 9101, Quincy, MA 02269-9101 Telephone (617) 770-3000 Fax (617) 770-0700 - www.nfpa.org.
- CGA Publication P-1: SAFE HANDLING OF COMPRESSED GASES IN CONTAINERS - Obtainable from Compressed Gas Association, 14501 George Carter Way, Suite 103, Chantilly, VA 20151 Telephone (703) 788-2700 Fax (703) 961-1831 - www.cganet.com.
- CSA W117.2 - Code for SAFETY IN WELDING AND CUTTING. - Obtainable from Canadian Standards Association, 178 Rexdale Blvd., Etobicoke, Ontario M9W 1R3 - www.csa.ca.
- ANSI Z87.1 - SAFE PRACTICE FOR OCCUPATION AND EDUCATIONAL EYE AND FACE PROTECTION - Obtainable from the American National Standards Institute, 11 West 42nd St., New York, NY 10036 Telephone (212) 642-9000, Fax (212) 398-0023 - www.ansi.org.
- NFPA 51B: STANDARD FOR FIRE PREVENTION DURING WELDING, CUTTING, AND OTHER HOT WORK- Obtainable from the National Fire Protection Association, 1 Batterymarch Park, P.O. Box 9101, Quincy, MA 02269-9101 Telephone (617) 770-3000 Fax (617) 770-0700 - www.nfpa.org.
- AWS C5.2 - RECOMMENDED PRACTICES FOR PLASMA ARC CUTTING AND GOUGING - obtainable from the American Welding Society, 550 NW Le Jeune Road, Miami, FL 33126 Telephone (800) 443-9353, Fax (305) 443-7559 - www.aws.org.

California Proposition 65 Warning

⚠ WARNING: This product can expose you to chemicals including lead, which are known to the State of California to cause cancer and birth defects or other reproductive harm. For more information go to www.P65Warnings.ca.gov. P65 details at forneyind.com. Wash hands after use.

EMF Information



Welding or cutting current, as it flows through the cables, will cause electromagnetic fields. There has been and still is some concern about such fields. However, after examination, the committee of the National Research Council concluded that: "The body of evidence, in the committee's judgment, has not demonstrated that exposure to power-frequency electric and a magnetic field is a human health hazard." However, studies are still going forth and evidence continues to be examined. Until the final conclusions of the research are reached, you may wish to minimize your exposure to electromagnetic fields when using machine.

To reduce magnetic fields in the workplace, use the following procedures:

1. Keep electrode and ground cables close together by twisting or taping them when possible.
2. Arrange cables to one side and away from the operator.
3. Do not coil or drape cables around your body.
4. Keep power source and cables as far away from operator as practical.
5. Connect ground clamp to workpiece as close to the cut or weld as possible.

ABOUT PACEMAKERS & HEARING AIDS: If you wear a pacemaker or hearing aids, please consult your doctor before using this product. If cleared by your doctor, following the above procedures is recommended.

Computers and computer driven equipment can be harmed with electromagnetic fields.

- Be sure all equipment is compatible with electromagnetic energy.
- Keep cables short to reduce interference.
- Follow manual to install and ground machine.
- If interference continues, shield the work area or move the machine.
- Locate cutting operation 100 meters from any sensitive electronic equipment.

Personal Protection



THE WELDING AND PLASMA CUTTING PROCESSES PRODUCES VERY BRIGHT ULTRAVIOLET AND INFRARED LIGHT. THESE ARC RAYS WILL DAMAGE YOUR EYES AND BURN YOUR SKIN IF YOU ARE NOT PROPERLY PROTECTED.

To reduce the risk of injury from arc rays, read, understand, and follow the safety instructions. In addition, please ensure anyone using this equipment or located near the work area understands and follows the safety precautions listed below.

- Helmets and filter should conform to ANSI Z87.1 standards.
- Do not look at a welding or plasma cutting arc without proper eye protection. A welding and plasma cutting arc is extremely bright and intense. Without adequate eye protection, your retinas may be severely burned, leaving permanent dark spots in your field of vision. Refer to ANSI Z49.1 or OSHA 29CFR for proper eye protection recommendations.
- Provide shields or helmets fitted with an appropriate shade filter lens to any bystanders.
- Do not strike an arc until all bystanders and the operator have shields and/or helmets in place.
- Do not wear a cracked or broken helmet and replace any cracked or broken filter lenses immediately.
- Do not allow the uninsulated portion of the MIG torch, TIG torch, Plasma torch or Electrode holder to touch the ground clamp or grounded workpiece to prevent an arc flash from being created on contact.
- Wear appropriate protective clothing. The intense light of the welding and plasma cutting arc can burn the skin in much the same way as the sun, even through lightweight clothing. Wear dark clothing made of heavy materials. The shirt worn should be long sleeved and the collar kept buttoned to protect your chest and neck.
- Protect yourself against reflected arc rays. Arc rays can be reflected off shiny surfaces such as a glossy painted surface, aluminum, stainless steel and glass. It is possible for your eyes to be injured by reflected arc rays even when wearing a protective helmet or shield. If working with a reflective surface behind you, arc rays may bounce off the surface and off the filter lens. These may enter your helmet or shield and damage your eyes. If a reflective background exists in your work area, either remove it or cover it with something non-flammable and non-reflective. Reflective arc rays may burn your skin in addition to damaging your eyes.
- Flying sparks may cause injuries to you or any bystanders. To avoid this, always wear approved safety glasses with side shields under your helmet or shield. Wear proper protection and work in a safe location whenever you shape a tungsten electrode on the grinder. Always keep flammables at a safe distance to prevent flying sparks from starting a fire.
- The heat and force from the plasma arc may cause serious burns. The danger of injury is greatly increased by the intensely hot and powerful arc, which can easily cut through gloves and tissue. To prevent injury, use the following precautions:
 - A. Keep away from the torch CUTTING TIP.
 - B. Do not grip material near the cutting path.
 - C. The pilot arc may cause burns - keep away from torch CUTTING TIP when trigger is pressed.
 - D. Wear proper flame-resistant clothing covering all exposed body areas.
 - E. Point PLASMA TORCH away from your body and toward workpiece when pressing the torch trigger – pilot arc comes on immediately.
 - F. Turn OFF machine and disconnect INPUT POWER CABLE before removing SHIELD CUP, changing torch consumables or disassembling PLASMA TORCH.
 - G. Use only the PLASMA TORCH that came with your plasma cutting machine or a certified replacement.



WARNING: FUMES, GASSES AND VAPORS MAY CAUSE DISCOMFORT, ILLNESS OR DEATH!

To reduce the risk of injury or death, read, understand, and follow these safety instructions. In addition, ensure anyone using this equipment or located near the work area also understands and follows the safety precautions listed below.

- Read and understand manufacturers Safety Data Sheets (SDS) and Material Safety Data Sheets (MSDS).
- Do not weld or plasma cut in an area until it is checked for adequate ventilation as described in ANSI standard Z49.1. If ventilation is not adequate to exchange all fumes and gasses generated during the welding or cutting process with fresh air, do not weld or cut unless you and all bystanders are wearing air-supplied respirators.

- Do not heat metals coated with, or that contain, materials that produce toxic fumes (such as galvanized steel), unless the coating is removed. Ensure the area is well ventilated, and the operator and all bystanders are wearing air-supplied respirators.
- When cutting aluminum underwater or with the water touching the underside of the aluminum, free hydrogen gas may collect under the workpiece and cause an explosion or injury.
- Do not weld, cut or heat lead, zinc, cadmium, mercury, beryllium, antimony, cobalt, manganese, selenium, arsenic, copper, silver, barium, chromium, vanadium, nickel, or similar metals without seeking professional advice and inspection of the ventilation of the work area. These metals produce extremely toxic fumes which can cause discomfort, illness or death.
- Do not weld or cut in areas that are near chlorinated solvents. Vapors from chlorinated hydrocarbons, such as trichloroethylene and perchloroethylene, may be decomposed by the heat of an electric arc or its ultraviolet radiation. These actions may cause phosgene, a highly toxic gas to form, along with other lung and eye-irritating gasses. Do not weld or cut where these solvent vapors may be drawn into the work area or where ultraviolet radiation may penetrate areas containing even very small amounts of these vapors.
- Do not use machine in a confined area unless there is proper ventilation or the operator (and anyone else in the area) is wearing an air-supplied respirator.
- Stop using immediately if you experience eye, nose or throat irritation, as this may indicate inadequate ventilation. Stop work and take necessary steps to improve ventilation in the work area. Do not resume use if physical discomfort persists.

Fire Prevention



WARNING: FIRE OR EXPLOSION MAY CAUSE DEATH, INJURY OR PROPERTY DAMAGE! To reduce these risks, read, understand and follow these safety precautions. In addition, ensure anyone using this equipment or located near the work area also understands and follows the safety precautions listed below. NOTE: Arc welding and plasma cutting by nature produces sparks, hot spatter, molten metal drops, hot slag and hot metal parts that may start fires, burn skin and damage eyes.

- Do not wear gloves or other clothing that contains oil, grease, or other flammable substances.
- Do not wear flammable hair products or accessories.
- Do not touch the hot weld bead, weld puddle or work material until it has fully cooled.
- When plasma cutting aluminum underwater or with the water touching the underside of the aluminum, free hydrogen gas may collect under the workpiece and cause an explosion.
- Do not weld or cut in an area until it is checked and cleared of combustible and/or flammable materials. Be aware that sparks and slag may fly 35 ft and can pass through small cracks and openings. If work and combustibles cannot be separated by a minimum of 35 ft, protect against ignition with suitable, snug-fitting, fire resistant covers or shields.
- Do not weld or cut into walls before checking for and removing any combustibles touching the other side of the wall.
- Connect the ground cable to the workpiece as close as possible to the work area. Do not connect ground cables to building framing or other locations away from the work area. This increases the possibility of the electrical current passing through alternate circuits, creating a fire hazard and other safety hazards.
- Do not weld, cut or work on used barrels, drums, tanks, or any other containers where flammable or toxic substances have been stored. The techniques used to remove flammable substances and vapors to make used containers safe for welding or cutting are quite complex and require specialized training. Never allow any electrically "hot" parts to touch a cylinder. Doing so will create a brittle area capable of becoming a violent rupture.
- Ensure any compressed gas cylinders in the work area have properly operating regulators rated for the gas and pressure used. All hoses, fittings, etc. should be in good condition.
- Do not stand in front of or put your head or face in front of a cylinder valve outlet when opening the valve.
- If a cylinder is not in use or connected for use, keep a valve protection cap in place to protect the valve.
- Keep cylinders upright and securely chain them to a fixed support to prevent tipping.
- Keep cylinders away from areas where they may be subjected to physical damage or accidentally struck. Keep them a safe distance from any source of flame, sparks or heat.
- Do not weld or cut in an area where the air may contain flammable dust (such as grain dust), gas or liquid vapors (such as gasoline).
- Never handle hot metal, such as the workpiece or electrode stubs, with bare hands.
- Always wear leather gloves, a heavy long-sleeved shirt, cuffless pants, high-topped and closed-toed shoes, a helmet and welding cap when operating this product. Use additional fire-resistant protective clothing to cover and protect the upper and lower body as needed. Hot sparks or metal may become lodged in rolled up sleeves, pant cuffs or

pockets. Keep your sleeves and collars buttoned at all times and use a shirt without pockets on the front. Keep long hair securely pulled back.

- Have fire extinguisher equipment handy in case of an emergency. A portable chemical fire extinguisher, type ABC, is recommended.
- Wear ear plugs when welding or cutting overhead to prevent spatter or slag from falling into your ears.
- Choose a work area with a solid, safe floor. Concrete or masonry is recommended. Avoid floors that are tiled, carpeted or containing any flammable material.
- Protect flammable walls, ceilings and floors with heat-resistant covers or shields.
- Always ensure your work area is free of sparks, flames or glowing metal or slag before leaving the area.
- Remove any combustibles such as lighters and matches before doing any welding or cutting.
- Do not overload building wiring – ensure the building power supply system is properly sized, rated and protected to handle this unit.
- Always ensure your work area is free of sparks, flames or glowing metal or slag before leaving the area.
- Follow OSHA and NFPA requirements for hot work and always keep an extinguisher nearby.

High-Frequency Radiation



- High-Frequency (H.F) can interfere with radio navigation, safety services, computers and communication equipment.
- It is your responsibility to have a qualified electrician promptly correct any interference problems resulting from the installation. An electrician should regularly check and maintain the installation.
- Stop using the equipment if notified by the FCC about interference.
- Keep H.F. source doors and panels tightly shut and keep spark gaps at the correct setting.

Electric Shock



WARNING: ELECTRIC SHOCK CAN KILL! To reduce the risk of death or serious injury from shock, read, understand and follow these safety instructions. In addition, ensure anyone using this equipment or located near the work area also understands and follows the safety precautions listed below.

WARNING: TO REDUCE THE RISK OF DEATH, INJURY OR PROPERTY DAMAGE, DO NOT ATTEMPT OPERATING the equipment until you have read and understand the following safety summary.

- Never make physical contact with any part of the welding or cutting current circuit. The welding and cutting current circuit includes:
 - a. The workpiece or any conductive material in contact with the welding/cutting current.
 - b. The ground clamp.
 - c. The electrode or welding wire.
 - d. Any metal parts on the electrode holder, TIG torch, MIG gun, or Plasma Torch.
- Plasma arc cutting requires higher voltages than welding to start and maintain the arc (200 to 400 volts DC are common). It also uses a plasma torch designed with safety interlock systems which turn the machine output off when the SHIELD CUP is loosened or if the CUTTING TIP touches the ELECTRODE during operation. Incorrectly installed or improperly grounded equipment is hazardous.
- Do not weld or cut in a damp area or come in contact with a moist or wet surface.
- Do not attempt to weld or cut if any part of your body or clothing is wet.
- Do not allow the machine to come in contact with water or moisture.
- Do not drag cables, MIG gun, TIG torch, Plasma torch, or machine's INPUT POWER CABLE through, or allow them to come into contact with, water or moisture.
- Do not touch the machine, or attempt to turn the equipment ON or OFF, if any part of your body or clothing is moist or if you are in physical contact with water or moisture.
- Do not attempt to plug the machine into the power source if any part of your body or clothing is wet or moist, or if you are in physical contact with water or moisture.
- Do not connect the ground clamp to electrical conduit and do not weld or cut on electrical conduit.
- Do not alter the INPUT POWER CABLE or plug in any way.
- Do not attempt to plug the machine into the power source if the ground prong on INPUT POWER CABLE plug is bent over, broken off or missing.

- Do not allow the machine to be connected to the power source or attempt to use if the machine, cables, work site or machine's INPUT POWER CABLE are exposed to any form of atmospheric precipitation or salt water spray.
- Do not carry coiled cables around your shoulders or any other part of your body when they are plugged into the machine.
- Do not modify any wiring, ground connections, switches or fuses in this equipment.
- Wear welding gloves to help insulate your hands from electrical circuit.
- Keep all liquid containers away from the machine and work area to prevent liquids from coming into contact with any part of the machine or electrical circuit.
- Immediately replace any cracked or damaged parts that are insulated or act as insulators, such as cables, INPUT POWER CABLE, plasma torch or electrode holder.
- When not MIG welding, cut the wire back to the contact tip. When not stick or TIG welding, remove the electrode from the electrode holder or TIG torch.

Noise



WARNING: Noise can cause permanent hearing loss. Welding and plasma cutting processes may create noise levels that exceed safe limits. You must always protect your ears from loud noise while operating this machine to prevent permanent hearing loss.

- To protect your hearing from loud noise, wear protective ear plugs and/or earmuffs.
- Noise levels should be measured to ensure the decibels (sound intensity) do not exceed safe levels.







Additional Safety Information



For additional information concerning welding and plasma cutting safety, refer to the standards listed at the beginning of this safety summary.

Box Contents



ITEM	DESCRIPTION	ITEM	DESCRIPTION	ITEM	DESCRIPTION
	Machine		Plasma Torch		10' Ground Cable w/Clamp
ITEM	DESCRIPTION	ITEM	DESCRIPTION	ITEM	DESCRIPTION
	Nylon Carry Strap		15-20A Plug Adapter		Additional Set of Consumables

Installation

Machine Specifications

Primary (Input) Volts	120VAC
Phase	Single
Frequency	50/60Hz
Maximum Output	20A
Recommended Circuit Breaker	120V - 20A time-delay (slow-blow) breaker minimum (30A for maximum performance) Refer to the ratings label and set the output amperage so that the listed input amperage is not exceeded.
Extension Cord Recommendations	120V - 3 conductor #12 AWG or larger up to 25'.
Generator Requirements	120V - Minimum 4,000W continuous output with no low-idle function (or low-idle off), 5% THD Max
CSA Rated Output and Duty-cycle	Refer to the data plate of your machine and the Duty-cycle section of this manual
Weight	17.3lbs. (7,9 Kg)
Dimensions	17.75" (451mm) X 6.6" (167,64mm) X 12.4" (314,96mm)
Cutting Capacity	Cleanly cut thin sheet metal to 1/4" plate (sever cut up to 3/8")

Site Selection



BE SURE TO LOCATE THE MACHINE ACCORDING TO THE FOLLOWING GUIDELINES:

- Position your machine near a 120V electrical outlet.
- Place at a distance of 12" or more from walls or similar obstructions that could restrict natural airflow for cooling.
- Arrange an open space workspace of at least 15' (5m) near the machine.
- In areas free from moisture and dust.
- In areas with ambient temperature between 30° to 90°F.
- In areas free from oil, steam and corrosive gases.
- In areas not subjected to abnormal vibration or shock.
- In areas not exposed to direct sunlight or rain.
- If the machine must be moved, always disconnect the INPUT POWER CABLE from the electrical outlet and gather the cables so as not to damage them.

Before you make any electrical connection, ensure the POWER SWITCH is OFF and the electrical circuit ratings meet those stated in the ratings label of your machine.

The main supply voltage should be within $\pm 10\%$ of the rated main supply voltage. Too low of a supply voltage may cause poor performance. Too high of a supply voltage will cause components to overheat and possibly fail. The electrical outlet must be:

- Correctly installed, if necessary, by a qualified electrician;
- Correctly grounded (electrically) in accordance with national and local regulations;
- Connected to an electric circuit that is rated for sufficient amperage per the ratings label of your machine.
- Check the electrical outlet for proper output voltage.
- Plug in the INPUT POWER CABLE to a 120V 20A electrical outlet (with a 30A time-delay breaker).
- A 120V 15A electrical outlet (with a 20A time-delay breaker) can be used with supplied adapter at lower output amperage settings.

If you are unsure of any of the above, have your outlet inspected by a qualified electrician before using the machine.

CHECK LOCAL AND NATIONAL ELECTRICAL CODES TO BE SURE THE USE OF A 30A BREAKER WITH A 20A ELECTRICAL OUTLET IS ALLOWABLE IN YOUR AREA.

NOTE:

- Periodically inspect the INPUT POWER CABLE for any cracks or exposed wires. If it is not in good condition, have it repaired by a Service Center.
- Do not cut off the grounding prong or alter the plug in any way. Only use the included adapter between the machine's INPUT POWER CABLE and the power source receptacle.
- Do not violently pull the INPUT POWER CABLE to disconnect it from electrical outlet.

Connect Input Power

- Do not lay material or tools on the INPUT POWER CABLE. The cable may be damaged and result in electrical shock.
- Keep the INPUT POWER CABLE away from heat sources, oils, solvents and sharp edges.
- Do not use this machine on a circuit with a Ground Fault Circuit Interrupter (GFCI). GFCIs are tripped by welding and cutting arcs and your operations will be interrupted regularly

Grounding Requirements

- To ensure personal safety, proper operation and to reduce electromagnetic interference (EMI), the machine must be properly grounded.
- The machine must be grounded through the INPUT POWER CABLE according to national and local electrical standards.
- Single-phase service must be of the 3-wire type with a green or green/yellow wire for the protective earth ground. Do not use 2-wire service.

Using the Power Adapter

If a 20A outlet (with 30A circuit breaker) is not available, you can connect your machine to 15A outlet (with a 20A circuit breaker) using the plug adapter. When using the plug adapter, use lower power settings on the machine to avoid frequent circuit breaker trips. At maximum settings, the machine will draw more than 20A regularly.

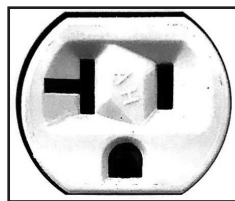

20A
(30A Circuit Breaker)

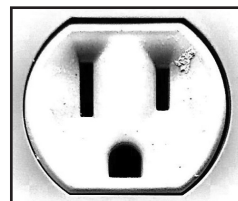

15A Outlet
(20A Circuit Breaker)

Generators

This machine can be operated from an AC generator. The generator must supply a minimum of 4,000W of continuous output. Do not use a generator with an auto-idle fuel saving feature unless it has the option to turn auto-idle off. The generator must always run at full speed while your machine is plugged into it to avoid damaging your machine. Any other power draws on the generator or anything that could reduce the generator RPM, may damage your machine. If the Total Harmonic Distortion (THD) of the generator exceeds 5% THD, it may damage your machine.

Extension Cords

For optimum machine performance, an extension cord should not be used unless absolutely necessary. If necessary, care must be taken in selecting an extension cord appropriate for use with your specific unit.

Select a properly grounded extension cord that will mate directly with the AC power source receptacle and the machine's INPUT POWER CABLE. Use only the included adapter if necessary to adapt the machine's INPUT POWER CABLE and the extension cord. Ensure that the extension cord is properly wired and in good electrical condition. Extension cords must fit the following wire size guidelines:

- Use #12 AWG or larger wire.
- Do not use an extension cord over 25' in length.

Ventilation

Since the inhalation of toxic fumes may be harmful, ensure that your work area is properly ventilated. See SAFETY SUMMARY of this manual for more details.

Additional Warnings

FOR YOUR SAFETY, CLOSELY FOLLOW THESE INSTRUCTIONS BEFORE CONNECTING THE POWER SOURCE TO THE OUTLET:

- An adequate two-pole breaker must be inserted before the main outlet. This breaker must be equipped with time-delay fuses.





- When working in a confined space, the machine must be kept outside the work area and the ground cable should be fixed to the workpiece. Never work in a damp or wet confined space.
- Do not use a damaged INPUT POWER CABLE or damaged cables.
- The welding or cutting torch/electrode should never be pointed at the operator or other people.
- The machine must never be operated without its panels attached. This could cause serious injury to the operator and could damage the equipment.

Getting to Know Your Machine

Description

Your new Forney TruCut™ plasma cutter is a powerful, compact and efficient machine. With 20A of cutting power and drag torch technology, it can easily clean-cut 1/4" of material while plugged into standard 120V household power. This machine is also lightweight and portable, weighing only 17.3lbs. Use the included nylon strap to carry your generator-friendly plasma cutter anywhere you need to go. Forney's innovative TruCut™ technology allows this machine to automatically set the ideal amperage based on the thickness of the material you indicate, saving you time and optimizing your workflow. Its 6' plasma torch allows you to step away from the cutting area if needed, while its bright and clear passive LCD display makes it easy to see the machine's settings, even from a distance.

Machine Layout and Controls

1. **PASSIVE LCD SCREEN:** Grants exceptional visual clarity and brightness allowing you to read your screen from afar.
2. **ADJUSTMENT KNOB:** Textured for ease of adjustment, even when wearing heavy gloves.
3. **POSITIVE DINSE CONNECTOR:** Connect the ground cable here, connect ground clamp to material being cut.
4. **PROCESS SELECTION BUTTON:** The Forney TruCut™ has two processes:
 -  **A. MANUAL PLASMA** – Traditional plasma cutting, use the Output Current Adjustment Knob to set the machine to the ideal amperage for the thickness of metal being cut.
 -  **B. TRUCUT™ PLASMA** – Use the Output Current Adjustment Knob until the thickness of the material you are cutting is shown on the screen. The machine will automatically set the output current to the ideal output for the thickness selected.
5. **DIGITAL DISPLAY:** Shows the set amperage when in Manual Plasma. Shows Material thickness when in TruCut™ Plasma.
6. **INDICATOR LIGHTS:**
 - A. TEMPERATURE LIGHT** - This light indicates a thermal fault, see troubleshooting guide for more information.
 - B. INPUT VOLTAGE LIGHT** - Light will be solid when the correct input power (120V) is present. Light will flash if input voltage is incorrect, see troubleshooting guide for more information.
 - C. TORCH LIGHT** - Light will be solid while cutting. Light will flash if a torch fault is occurring, see troubleshooting guide for more information.
7. **MATERIAL THICKNESS INDICATOR:** Will show when the unit is in TruCut™ Plasma, indicating the adjustment knob changes material thickness.
8. **AMPERAGE ADJUSTMENT INDICATOR:** Amp will show when the unit is in Manual Plasma, indicating the adjustment knob adjusts output amperage.
9. **NUMERIC DISPLAY UNIT INDICATOR:** Indicates the unit of the numbers shown on the display.
 - A. A** - Amperage. Seen in Manual Plasma.
 - B. ga** - Gauge. Seen in TruSet™ Plasma.
 - C. in** - Inches. Seen in TruSet™ Plasma.
10. **PROCESS INDICATOR:** Will display which process the machine is set to.
 -  **A. MANUAL PLASMA** – Traditional plasma cutting, use the Output Current Adjustment Knob to set the machine to the ideal amperage for the thickness of metal being cut.
 -  **B. TRUCUT™ PLASMA** – Use the Output Current Adjustment Knob until the thickness of the material you are cutting is shown on the screen. The machine will automatically set the output current to the ideal output for the thickness selected.
11. **POWER SWITCH:** Turns the machine ON and OFF. (Make sure the POWER SWITCH is in the OFF position before performing any maintenance on the machine).
12. **COMPRESSED AIR INPUT:** 1/4" I/M fitting.
13. **MOISTURE SEPARATOR:** The filter has automatic drain. When compressed air is disconnected, the filter will drain.
14. **HANDLE:** Rugged, top mounted handle allows for easy transport of your plasma cutter and a place to wrap your cables.
15. **INTEGRATED PLASMA TORCH STRAIN RELIEF:** The torch is permanently attached to the machine. A protective housing covers the torch lead attachment to the machine.

REAR VIEW OF FORNEY TRUCUT™

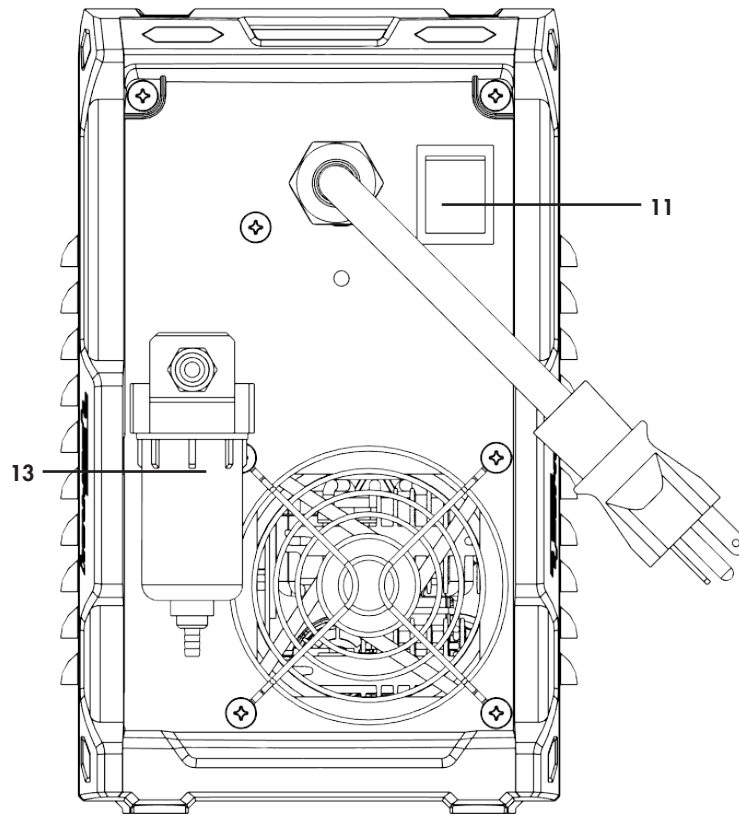

FRONT VIEW OF FORNEY TRUCUT™

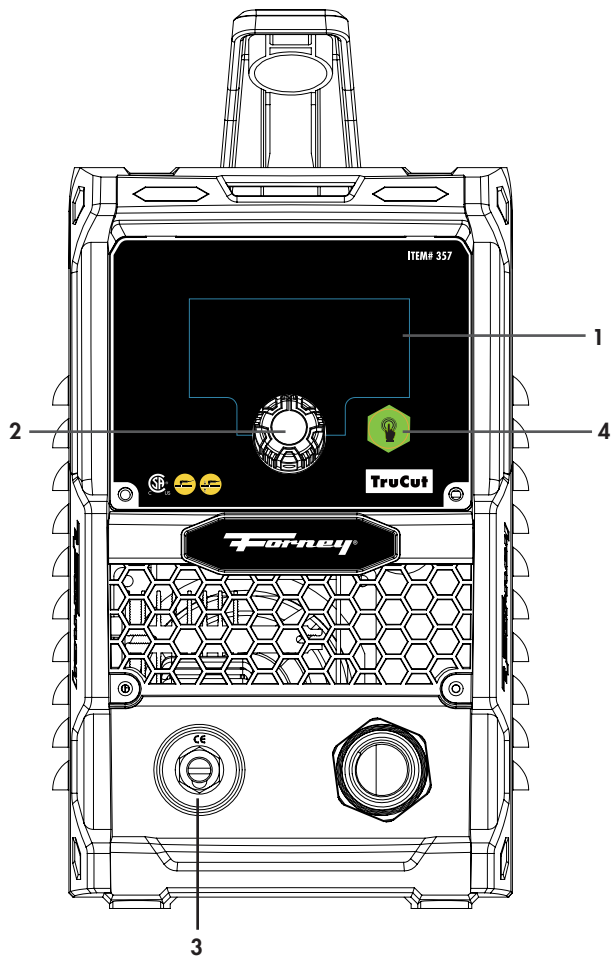

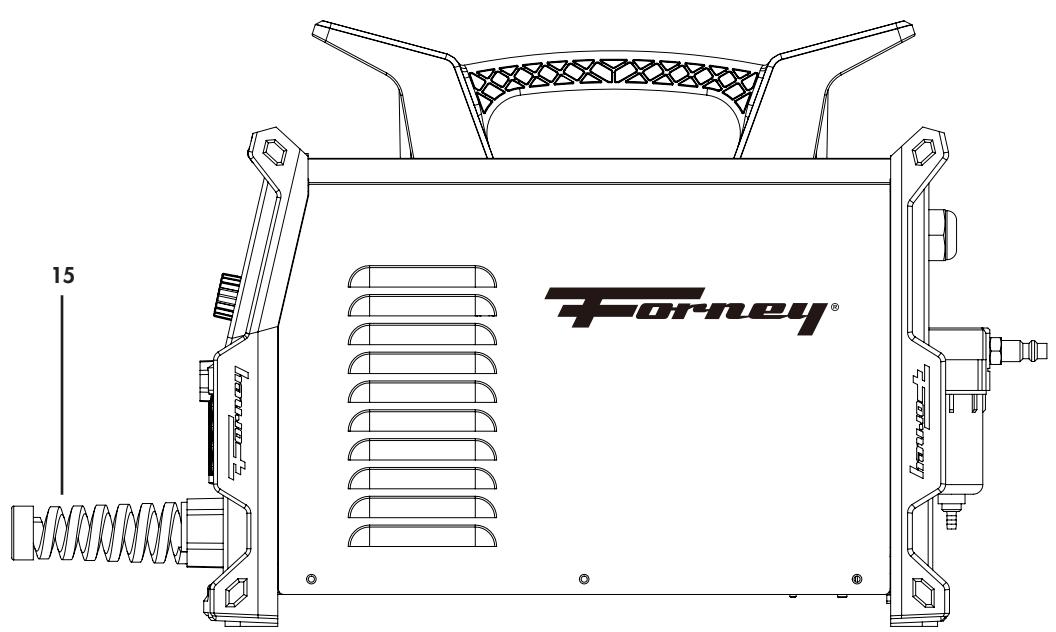
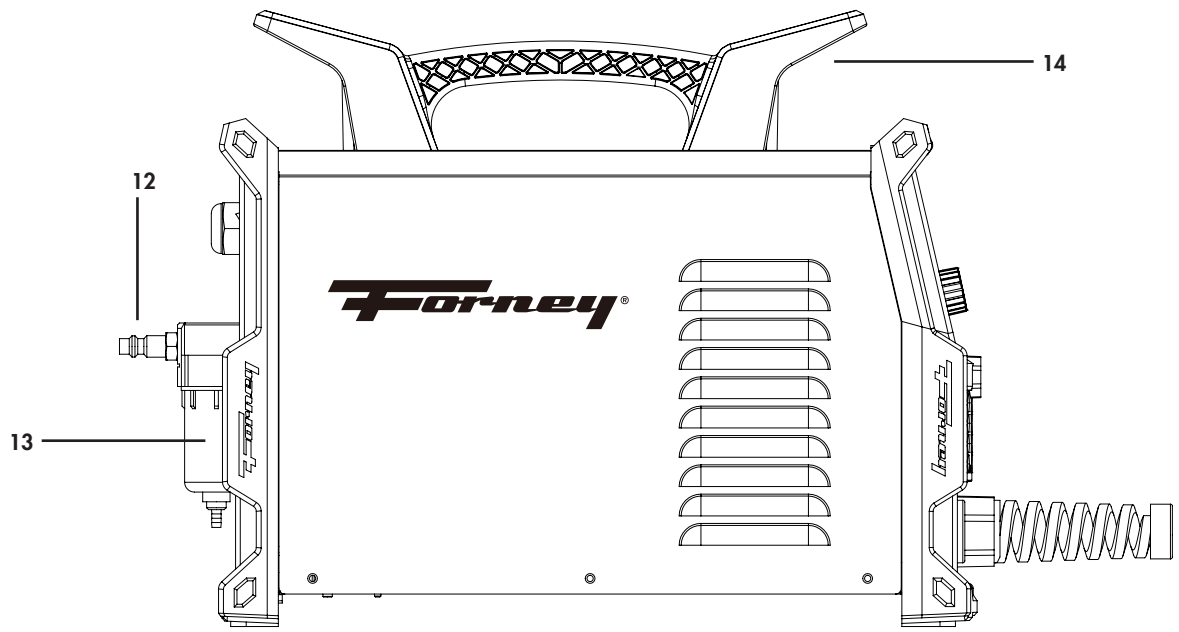

Compressed Gas Supply

- The plasma cutting machine does not include a built-in air compressor; therefore, a source of clean, dry air or nitrogen must be supplied to your plasma cutting unit.
- The air supply pressure must be between 60 and 100 PSI. NOTE: The recommended flow rate is 2.5 cu.ft/min. Minimum flow rate must be at least 1.5 cu.ft/min.
- The unit will not operate if the input air pressure is below 55 PSI.
- Do not connect an input air supply over 100 PSI. Damage to the machine could occur.
- In-line particulate filtration is recommended upstream of the PLASMA CUTTING MACHINE to avoid damage to the PLASMA TORCH.
- Failure to observe these parameters could result in excessive operating temperatures and/or damage to the PLASMA TORCH or machine.

Moisture Separator and Automatic Purge

- Oil and moisture in the air may damage the machine.
- The unit is equipped with an air filter, which captures the water and oil vapor in the supplied air.
- Water captured by the filter is automatically purged through the bottom of the machine.
- The equipped moisture separator is designed to remove small amounts of moisture and oil from the air supply. If you are operating in a humid environment, it may be necessary to put additional filtering in the air supply line before its input to the machine. Use additional filtering if a spray of moisture can be seen coming out of the torch head during pilot arc, if there are signs of moisture on the CUTTING TIP/NOZZLE or workpiece after cutting, or if the cut quality is poor.
- Be sure and to select a filter that is rated for the pressure and air flow requirements listed above.

Air Supply Quality

To check supplied air quality, activate and deactivate the PLASMA TORCH so there is no active arc, but air flow continues (post-flow). Place a piece of steel in front of the PLASMA TORCH. Any oil or moisture in the air will be visible on the lens.

DO NOT INITIATE PILOT ARC WHILE CHECKING AIR QUALITY.

Torch Consumable Parts (ITEM# 78011)



USE ONLY THE PLASMA TORCH THAT CAME CONNECTED TO YOUR MACHINE OR A CERTIFIED REPLACEMENT.



CAUTION! DISCONNECT INPUT POWER CABLE FROM THE ELECTRICAL OUTLET AND WAIT FOR THE PLASMA TORCH TO COOL BEFORE REMOVING THE SHIELD CUP. IT IS EXTREMELY IMPORTANT THAT YOU CAREFULLY READ THESE INSTRUCTIONS BEFORE CHOOSING THE CONSUMABLES FOR YOUR PLASMA TORCH. THIS WILL PREVENT DAMAGE TO YOUR PLASMA TORCH AND MACHINE.

BEFORE BEGINNING CUTTING OPERATIONS, VERIFY THAT THE PARTS ARE PROPERLY ASSEMBLED BY INSPECTING THE BODY OF THE PLASMA TORCH AS SHOWN BELOW.



THE PLASMA ARC FROM INSTANT-ON TORCHES MAY CAUSE INJURY AND BURNS.



CAUTION! The plasma pilot arc comes on immediately when the torch trigger is activated. Ensure the POWER SWITCH is OFF and the machine is disconnected before changing consumables.



PROPERLY ASSEMBLED PLASMA TORCH

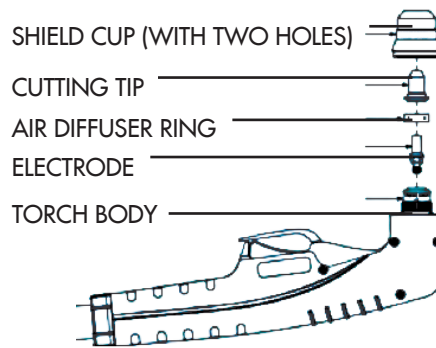

PROPER CONSUMABLE ASSEMBLY FOR PLASMA TORCH HEAD

Your PLASMA TORCH consumable parts will come already assembled. Plasma torch consumables will wear through the course of normal use and need to be replaced periodically. Before each use of the plasma cutting machine, you should check your parts for wear and replace them if necessary. NOTICE: Failure to replace worn CUTTING TIP/NOZZLE or ELECTRODE may damage the PLASMA TORCH.

Before inspecting or replacing the consumables, make sure to read and follow the below notes:

1. Turn the machine OFF and disconnect it from the electrical outlet. **Wait for the PLASMA TORCH to cool before disassembly.**
2. Position the PLASMA TORCH with the SHIELD CUP facing upward to prevent these parts from falling out.
3. Unscrew and remove the SHIELD CUP from the TORCH BODY.
4. Remove the CUTTING TIP/NOZZLE, AIR DIFFUSER RING and ELECTRODE.
5. Install the ELECTRODE, AIR DIFFUSER RING, and CUTTING TIP/NOZZLE. If any of these are worn or damaged, replace them immediately.
 - Ensure all components are installed as shown above.
 - Finger tighten the ELECTRODE. A loose ELECTRODE may further loosen during operation and damage the PLASMA TORCH. **DO NOT OVERTIGHTEN THE ELECTRODE. OVERTIGHTENING MAY DAMAGE THE TORCH BODY.**
6. Ensure the SHIELD CUP is properly seated on the TORCH BODY, not cross-threaded. Failure to do so will cause the machine to operate improperly. Only hand-tighten the SHIELD CUP. Overtightening may damage the PLASMA TORCH.

If resistance is felt when installing the ELECTRODE or SHIELD CUP, check the threads before proceeding.

NOTE: THE MACHINE WILL NOT OPERATE UNLESS THE PLASMA TORCH SHIELD CUP IS FULLY SEATED AGAINST THE PINS THAT ENSURE THE CONSUMABLES ARE PROPERLY ASSEMBLED TO THE TORCH BODY. INSPECT THESE PINS FOR DAMAGE ANYTIME THE SHIELD CUP IS REMOVED.

USE ONLY FORNEY BRAND CONSUMABLES IN YOUR PLASMA TORCH. USING INCOMPATIBLE PARTS MAY DAMAGE YOUR MACHINE OR INTRODUCE A SAFETY HAZARD. SEE THE "CONSUMABLE DIAGRAMS" SECTION OF THIS MANUAL FOR PART NUMBERS.

Operation







Performance Data Plate and Duty-Cycle

The data plate of a machine holds a lot of information. This includes the machine name, process and various duty cycle charts, among other things. While the below section does not show the actual data found on your machine, it does provide you with the tools needed to understand any data plate regardless of model or brand.

The duty-cycle rating of a machine defines how long the operator can work and how long the machine must rest and be cooled. Duty-cycles are expressed as a percentage of 10 minutes and represents the maximum work time allowed. The balance of the 10-minute cycle is required for cooling. It is common for machines to show three separate rates, showing the difference in duty cycle based on the set output. For example, using a machine with a duty-cycle rating of 30% at the rated output of 90A, you can weld/cut at 90A output for three (3) minutes out of 10 with the remaining seven (7) minutes required for cooling. A sample of the data plate can be found in the diagram below. A completed data plate with duty-cycle and other specifications can be found affixed to the machine. Referring to the sample below, J., K., and L. list duty-cycle percentages while P., Q., and R. list the output amperage and T., U., and V. list the output voltage. Various duty-cycles at other amperages/voltages are listed on your data plate.

The data plate also shows both the maximum amperage draw, Y., for a given input voltage, X. Data plates can be very complex and show duty cycle rates for different input voltages and breaker sizes. Pay close attention to the breaker on the circuit the machine is plugged into and follow the appropriate ratings. User settings on the machine may need to be reduced or limited to avoid exceeding the rated input amperage. Failure to do so could result in frequent breaker trips or electrical hazards.

Machines capable of multiple processes and/or multiple input powers will see sections F-Z, below, repeated on the data plate for every combination of process and input power (voltage and breaker size) the machine is capable of.

Forney Industries 2057 Vermont Drive, Fort Collins, CO 80525 A			
B Machine Name		C Serial Number:	
D 		E 	
F 	G 	H Minimum AMP/Volt to Maximum AMP/Volt	
M 	N $U_0 = \text{###}V$	I X	J ###%
		O I_2	P ###A
		S U_2	Q ###A
			R ###A
W  1-50/60Hz	X $U_1 = \text{###}$	Y $I_{1\text{max}} = \text{###}A$	Z $I_{1\text{eff}} = \text{###}A$
		K ###%	L ###%
		T ###V	U ###V
		V ###V	

- a. Manufacturer.
- b. Machine name.
- c. Serial number.
- d. Electrical phase line diagram.
- e. Independent product safety certificates
- f. Process diagram:



- g. Signifies the output current:



- h. Minimum output amperage/voltage to maximum output amperage/voltage
- i. Duty cycle chart
- j. Duty cycle rating #1
- k. Duty cycle rating #2
- l. Duty cycle rating #3
- m. Identifies a power source suitable for use in an environment with an increased risk of electric shock
- n. $U_{(0)}$ indicates the open circuit voltage
- o. $I_{(2)}$ indicates the output amperage the duty cycle above it represents
- p. Output amperage of duty cycle rating #1
- q. Output amperage of duty cycle rating #2
- r. Output amperage of duty cycle rating #3

- s. $U_{(2)}$ indicates the output voltage that the duty cycle above it represents
- t. Output voltage of duty cycle rating #1
- u. Output voltage of duty cycle rating #2
- v. Output voltage of duty cycle rating #3
- w. Indicates input power phase and hertz requirements
- x. $U_{(1)}$ indicates the input power voltage: This indicates the input power voltage of the machine for the duty cycle chart shown. Multi-voltage machines will have both 120V and 240V duty cycle charts. This will indicate which chart is shown here.
- y. $I_{(max)}$ indicates the maximum amperage draw: Metal working machines have a high amperage draw when initiating the arc. It is brief and will drop to the running amperage once the arc is initiated.
- z. $I_{(1eff)}$ indicates the running amperage: This is the maximum running amperage draw of the machine while operating under normal conditions, after arc initiation and at the highest output settings.

Internal Thermal Protection

If you exceed the duty-cycle of the machine, the thermal protection system will engage and shut off all machine output. After cooling, the thermal protector will automatically reset and the welding or cutting functions can resume. This behavior is normal and automatic and does not require any user action. However, you should wait at least 10 minutes after the thermal protector engages before resuming welding or cutting. You must do this even if the thermal protector resets itself before the ten minutes is up or you may experience less than specified duty-cycle performance.

CAUTION: DO NOT REGULARLY EXCEED THE DUTY-CYCLE OR DAMAGE TO THE MACHINE CAN RESULT.

Welding and Cutting Preparation

An important factor in making a satisfactory weld or cut is preparation. This includes studying the process and equipment and practicing welding or cutting before attempting to complete a finished product. An organized, safe, ergonomic, comfortable and well-lit work area should be prepared for the operator. To make the work area safe, all combustible materials should be kept a safe distance away and a fire extinguisher and bucket of sand should be kept near the work area at all times.

To properly prepare for welding or cutting with your new machine, it is necessary to:

- Read the safety precautions at the front of this manual.
- Prepare an organized, well-lit work area.
- Provide protection for the eyes and skin of the operator and bystanders.
- Attach the ground clamp to the bare metal to be welded or cut, ensuring good contact.
- Plug the machine into a suitable outlet.
- Completely open the gas cylinder valve. Adjust the gas pressure regulator to the correct flow rate. (Not applicable to stick "SMAW", flux-core "FCAW" or cut processes.)
- Provide a source of clean, dry air or nitrogen. (Only applicable for Plasma Cutting).



EXPOSURE TO A WELDING OR CUTTING ARC IS EXTREMELY HARMFUL TO THE EYES AND SKIN. PROLONGED EXPOSURE TO A WELDING OR CUTTING ARC MAY CAUSE BLINDNESS AND BURNS. NEVER STRIKE AN ARC OR BEGIN WELDING UNLESS YOU ARE ADEQUATELY PROTECTED. WEAR FIRE-RESISTANT WELDING GLOVES, A LONG-SLEEVED SHIRT, CUFFLESS PANTS, HIGH-TOPPED SHOES AND A WELDING HELMET.

Ground Clamp Connection

Connect the GROUND CABLE CLAMP to the workpiece to be cut or welded, or to the metallic workbench.

Take following precautions:

- Ensure that the GROUND CLAMP is attached with a good connection to an area of the workpiece that is clean and free from any coatings such as paint, rust, oil/grease or scale.
- Make ground connections as close as possible to the work area to reduce EMI.
- When plasma cutting, do not make a ground connection on the piece which is to be removed.

Cutting

IMPORTANT! Frequently review the Important Safety Precautions at the front of this manual.



CAUTION! The operator should always be equipped with proper gloves, clothing and eye & ear protection. Ensure no part of the operator's body comes into contact with the workpiece while the PLASMA TORCH is activated.



CAUTION! Sparks from the cutting process may cause damage to coated, painted and other surfaces, such as glass, plastic and metal.

Fig. A

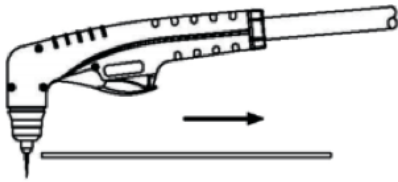
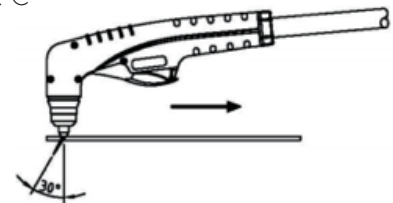

Fig. B



Fig. C



CUTTING WITH A HAND TORCH

- The PLASMA TORCH can be comfortably held in one hand or steadied with two hands. Choose the technique that feels most comfortable and allows good control and movement. Position your index finger or thumb to press the trigger on the PLASMA TORCH handle.
- With the PLASMA TORCH in starting position, press the trigger. The pilot arc will come on and remain on for three seconds during which the CUTTING TIP/NOZZLE must come into contact with the workpiece.
- In the event the CUTTING TIP/NOZZLE does not come into contact with the workpiece within three seconds of pilot arc start, the arc will stop automatically (the post flow air will continue to run, cooling the PLASMA TORCH).
- For edge starts, hold the PLASMA TORCH perpendicular to the workpiece with the front of the CUTTING TIP/NOZZLE on the edge of the workpiece at the point where the cut is to start (Fig. A). For piercing, angle the PLASMA TORCH slightly to direct the sparks away from the PLASMA TORCH until the pierce is complete (Fig. B).
- While cutting, the CUTTING TIP/NOZZLE must be kept in contact with the workpiece. If contact is lost, the arc will stop automatically (the post flow air will continue to run, cooling the PLASMA TORCH).
- Once started, the cutting arc will remain on as long as the trigger is pressed, unless the PLASMA TORCH is withdrawn from the workpiece or torch motion is too slow. Keep moving while cutting. Cut at a steady speed without pausing. Maintain the cutting speed so that the arc lag is about 30° behind the travel direction (Fig. C).
- Adjust the torch speed so sparks go through the metal and out the bottom of the cut at that angle.
- If sparks are being blown upward and back at the CUTTING TIP/NOZZLE, your torch travel speed is too fast. Decrease your travel speed.
- Pause at the edge (end of your cut) until the arc has cut completely through the workpiece.
- To shut off the PLASMA TORCH, simply release the trigger. When the trigger is released, a post-flow will occur. If the torch trigger is pressed during the post-flow, the pilot arc will restart.
- Refer to the TROUBLESHOOTING section of this operating manual should the PLASMA TORCH or plasma cutting machine not operate as expected.

Fig. B

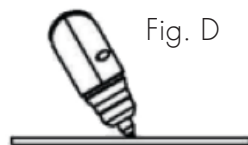

Fig. D

Fig. D

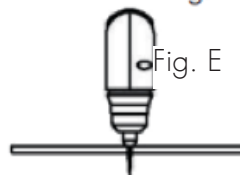

Fig. E

PIERCING WITH A HAND TORCH

NOTE: If you need to make a cut on a metal sheet that is thicker than the maximum piercing capacity (without an edge start), make a 1/4" hole using an electric drill to start cutting.

- When piercing with a hand torch, tilt the PLASMA TORCH slightly so that blowback particles blow away from the CUTTING TIP/NOZZLE (and operator) rather than directly back into it (Fig. D).

- Complete the pierce off the cutting line and continue the cut onto the line. Hold the PLASMA TORCH perpendicular to the workpiece after the pierce is complete (Fig. E).
- Clean spatter and scale from the SHIELD CUP and the CUTTING TIP/NOZZLE as soon as possible. Spraying the consumables in anti-spatter compound will minimize the amount of scale which adheres to it.
- Refer to the TROUBLESHOOTING section of this operating manual should the PLASMA TORCH or plasma cutting machine not operate as expected.

During cutting operations, performance faults may occur which are caused not by equipment malfunction but by other operational faults, such as:

1. The cut speed is too fast.
2. The consumables are worn.
3. The metal being cut is too thick.
4. The GROUND CLAMP is not properly attached to the workpiece.
5. The supplied air pressure and flow rate is inadequate.
6. Input power is insufficient (use of extension cords can cause this).
7. PLASMA TORCH is not being dragged in contact with the workpiece

MILD STEEL	STAINLESS STEEL	ALUMINUM	GALVANIZED	BRASS	COPPER	
1/4"	1/4"	1/8"	1/4"	1/4"	1/4"	3/8"
RECOMMENDED CAPACITY						SEVER CAPACITY
<ul style="list-style-type: none"> • Optimal system performance. • Ideal operating range for excellent cut quality. • Rated with new consumables. 						<ul style="list-style-type: none"> • Top end of machine capabilities. • Intended for occasional severance requirements; where a lower degree of cut quality is acceptable. • Slower cut speeds.

Maintenance & Servicing

General Maintenance

This machine has been engineered to need minimal service providing that a few very simple steps are taken to properly maintain it.



WARNING: ELECTRIC SHOCK CAN KILL! Be aware that the ON/OFF SWITCH, when OFF, does not remove power from all internal circuitry in the machine. To reduce the risk of electric shock, always unplug the unit from its AC power source and wait several minutes for electrical energy to discharge before removing the side panels:

1. Always keep the cabinet cover closed unless changing the wire or the drive pressure.
2. Keep all consumables clean and replace them when necessary. See "Consumable Maintenance" (below) and "Troubleshooting" for detailed information.
3. Replace INPUT POWER CABLE, ground cable, ground clamp, welding torch or plasma torch if damaged or worn.
4. Avoid directing grinding particles towards the machine. These conductive particles can build up inside the machine and cause severe damage.
5. Periodically clean dust, dirt, grease, etc. from your machine. Every six months or as necessary, remove the cover from the machine and use compressed air to blow out any dust and dirt that may have accumulated inside the machine.
6. Check all cables periodically. They must be in good condition and not cracked.

Consumable & Machine Maintenance

DISCONNECT THE INPUT POWER CABLE FROM THE ELECTRICAL OUTLET AND WAIT FOR THE PLASMA TORCH TO COOL BEFORE REMOVING THE SHIELD CUP OR PERFORMING MAINTENANCE.



CAUTION! Maintenance can only be carried out on the unit if the operator has the necessary technical knowledge and the correct tools. If this is not the case, contact your nearest service center.



CAUTION! Never access inside the machine (panel removal) or touch the torch head (disassembly) without disconnecting the INPUT POWER CABLE first.

ANY INSPECTION PERFORMED WHILE INPUT POWER VOLTAGE IS PRESENT INSIDE THE MACHINE OR INSIDE THE PLASMA TORCH MAY CAUSE SEVERE ELECTRIC SHOCKS CAUSED BY DIRECT CONTACT WITH PARTS UNDER VOLTAGE.



CAUTION! Use only dry compressed air for cleaning. Do not point the air jet at the electronic circuits contained within this plasma cutting machine.

Your plasma cutting machine must routinely receive maintenance to keep the system in optimal working condition and to provide long-term value for your investment. It is recommended to inspect the unit every 3-4 months (depending on the frequency of use).

- Use compressed air to remove any dust deposits.
- The torch SHIELD CUP and CUTTING TIP/NOZZLE should be periodically inspected for wear or damage.
- Replace the CUTTING TIP/NOZZLE if the orifice becomes damaged or enlarged.
- If consumable surfaces are particularly oxidized, clean them with an extra-fine abrasive.
- Replace the AIR DIFFUSER RING if it is burned or cracked.
- Replace the ELECTRODE when the crater on the end surface is approximately 1/16.".

FAILURE TO MAINTAIN THE PLASMA CUTTING MACHINE, CONSUMABLES AND THE WORKING ENVIRONMENT WILL DECREASE THE SYSTEM'S PERFORMANCE AND PRODUCE RESULTS BELOW OPTIMAL PERFORMANCE LEVELS.

FREQUENCY	PERIODIC MAINTENANCE TO BE PERFORMED
Each Use	<ul style="list-style-type: none"> • Check the indicator lights/LEDs and correct any fault conditions. • Check & clean the SHIELD CUP, CUTTING TIP/NOZZLE, AIR DIFFUSER RING and ELECTRODE for proper installation, wear, damage (burns, distortions or cracks), dirt, debris and restricted holes.
Weekly	<ul style="list-style-type: none"> • Verify the operation of the SHIELD CUP shut-down system. (Remove the SHIELD CUP and pull the trigger. The pilot arc should not start.)
3 Months	<ul style="list-style-type: none"> • Check for and replace any cracked or damaged parts. • Check the torch trigger guard for damage. • Check the TORCH BODY (A) and trigger for wear, exposed wires or damage and replace them as required. • Check the outer covering of all cables for wear and replace them as required.
6 Months	<ul style="list-style-type: none"> • Blow out or vacuum inside.





CAUTION! Inspect the SHIELD CUP, CUTTING TIP/NOZZLE, AIR DIFFUSER RING and ELECTRODE for wear and debris before cutting or whenever the cutting speed has been significantly reduced.



CAUTION! Do not operate the PLASMA TORCH without a CUTTING TIP/NOZZLE or ELECTRODE in place. Be sure to use genuine Forney parts.

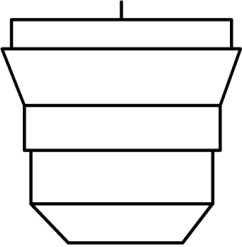
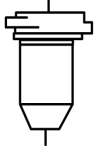
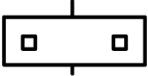
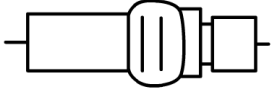
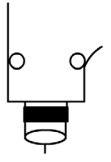

NOTE: It is recommended that the ELECTRODE and CUTTING TIP/NOZZLE be replaced at the same time to ensure even wear and optimal performance.

PART		INSPECT	ACTION
	Shield Cup	The center hole for roundness.	Replace the SHIELD CUP if the hole is no longer round.
		The gap between the SHIELD CUP and CUTTING TIP for accumulated debris.	Remove the SHIELD CUP and clean any debris away. Replace the shield cup if it is damaged or uncleanable.
		Examine for cracks, burn-through or chips.	Replace the SHIELD CUP if it is cracked, burned-through or chipped.
	Cutting Tip / Nozzle	The center hole for roundness and/or enlargement.	Replace the SHIELD CUP if the hole is no longer round or enlarged.
		Oxidized exterior.	Can be cleaned with an extra-fine abrasive cloth without using solvents.
	Air Diffuser Ring	Verify there are no burns or cracks and that the airflow holes are not obstructed.	Replace the AIR DIFFUSER RING if it is damaged.
	Electrode	The center surface for wear and verify pit depth.	Replace the ELECTRODE when the crater on the emitting surface about 1/16" (2mm) deep.
	Torch Body	Check the surface for damage, wear and debris.	If debris is present, clean it without using solvents.
			Replace the PLASMA TORCH if the TORCH BODY is damaged, cracked or worn.
	Torch Handle & Cable	These parts usually do not require maintenance except for a periodic inspection and cleaning.	If debris is present, clean it without using solvents.
			Replace the PLASMA TORCH if any part of the handle or cable is cracked or worn.
			DO NOT touch the PLASMA TORCH and cable with warm or hot parts.
			DO NOT strain the cable.
			DO NOT move the cable over sharp edges or abrasive surfaces.
	Ground Clamp & Cable	These parts usually do not require particular maintenance with the exception of a periodic inspection and cleaning.	Follow the same actions as with the TORCH HANDLE and CABLE.
			Additionally, ensure there is no corrosion on the GROUND CLAMP contact surfaces.

Troubleshooting

During cutting operations, performance faults may arise which are not caused by malfunctioning equipment but by other operational faults such as:



1. The cut speed is too fast.
2. The consumables are worn.
3. The metal being cut is too thick.
4. The GROUND CLAMP is not properly attached to the workpiece.
5. The supplied air pressure and flow rate is inadequate.
6. The input power is insufficient (use of extension cords can cause this).
7. The PLASMA TORCH is not being dragged in contact with the workpiece.

PROBLEM	POSSIBLE CAUSE	POSSIBLE SOLUTION
	Consumables are missing or improperly installed.	Check the PLASMA TORCH consumables are properly installed. See the "Torch Consumables Parts" and "Consumable Maintenance" sections of this manual.
	The consumables are excessively worn.	Replace the electrode and cutting tip/nozzle.
	The electrode cannot make contact with the tip to initiate the arc. The cause could be excessively worn consumables, oxidation, residue inside the cutting tip or a mechanical failure.	Replace the consumables, including the Air Diffuser and electrode base with spring.
The PLASMA TORCH has a pilot arc but does not cut.	The GROUND CLAMP is disconnected.	Properly connect the GROUND CLAMP to the workpiece. Ensure it is on clean, bare metal (not rusty or painted).
	The AC input power is too low.	Ensure the plasma cutting machine has the proper input power source. Eliminate or reduce the length of the extension cord if one is being used.
The arc does not transfer to the workpiece.	Insufficient GROUND CLAMP contact with the workpiece.	Clean the area where the GROUND CLAMP attaches to the workpiece to ensure a good metal to metal connection. Inspect the GROUND CLAMP and its lead for damage. Repair or replace it as needed.
	The PLASMA TORCH may not be in contact with the workpiece.	Be sure to physically drag the CUTTING TIP/NOZZLE on the workpiece as you cut.
Poor cut quality.	Improper use of the PLASMA TORCH.	Review operating instructions.
	The PLASMA TORCH parts are worn out.	Examine the consumables for wear and replace any worn parts with new Forney consumable parts.
	There is moisture or oil in the air supply.	Excessive humidity or oil from the compressor may be contaminating the air supply. Install a moisture filter in the air supply line between the air compressor and the machine.

PROBLEM	POSSIBLE CAUSE	POSSIBLE SOLUTION
Moisture is coming out of the PLASMA TORCH.	There is moisture or oil in the air supply.	Excessive humidity or oil from the compressor may be contaminating the air supply. Install a moisture filter in the air supply line between the air compressor and the machine.
Sparks are being blown upward and back at the PLASMA TORCH CUTTING TIP/NOZZLE.	The cutting speed is too fast.	Decrease your torch travel speed.
	The workpiece is too thick.	Choose a thinner workpiece material within the operational limits of the plasma cutting machine.
Insufficient cut penetration.	The cutting speed is too fast.	Decrease your torch travel speed.
	The PLASMA TORCH is too tilted.	Ensure the PLASMA TORCH is perpendicular to the workpiece.
	The workpiece is too thick.	Choose a thinner workpiece material within the operational limits of the plasma cutting machine.
	The cutting current is too low.	Turn the current setting up.
		Ensure the plasma cutting machine has the proper input power source.
	Eliminate or reduce the length of the extension cord if one is being used.	
The PLASMA TORCH parts are worn out.	Examine the consumables for wear and replace any worn parts with new Forney consumable parts.	
Non-genuine manufacturer's parts are being used.	Use only genuine Forney consumables for optimum performance.	
The cutting arc is interrupted, but it reignites when it is triggered again.	The cutting speed is too slow.	Increase your torch travel speed.
	The PLASMA TORCH may not be in contact with the workpiece.	Be sure to physically drag the CUTTING TIP/NOZZLE on the workpiece as you cut.
	The AC input power is too low.	Ensure the plasma cutting machine has the proper input power source.
		Eliminate or reduce the length of the extension cord if one is being used.
	The PLASMA TORCH parts are worn out.	Examine the consumables for wear and replace the worn parts with new Forney consumable parts.
	Non-genuine manufacturer's parts are being used.	Use only genuine Forney consumables for optimum performance.
The GROUND CABLE is disconnected.	Securely CLAMP the GROUND CABLE to the material being cut, as close to the work area as possible.	

PROBLEM	POSSIBLE CAUSE	POSSIBLE SOLUTION
Excessive dross.	The cutting speed is too slow (bottom dross).	Increase your torch travel speed.
	The cutting speed is too fast (top dross).	Decrease your torch travel speed.
	The cutting current is too low.	Ensure the plasma cutting machine has the proper input power source.
		Eliminate or reduce the length of the extension cord if one is being used.
	The PLASMA TORCH parts are worn out.	Examine the consumables for wear and replace any worn parts with new Forney consumable parts.
Non-genuine manufacturer's parts are being used.	Use only genuine Forney consumables for optimum performance.	
Tilted cut edge angle (not perpendicular).	The PLASMA TORCH position not correct.	Ensure the PLASMA TORCH is perpendicular to the workpiece.
	The workpiece thickness is near the capacity of the machine.	Cut a thinner material.
	Asymmetric wear of the CUTTING TIP/NOZZLE hole and/or wrong assemblage of the PLASMA TORCH parts.	Check all PLASMA TORCH consumables for wear and proper installation.
Examine the consumables for wear and replace worn parts with new Forney consumable parts.		
Excessive wear of the CUTTING TIP/ NOZZLE or ELECTRODE.	The air pressure is too low.	Inspect the air compressor, air lines and filters for proper operation.
		Inspect all consumables for obstructions and proper installation.
	Exceeding the plasma cutting machine's capabilities (the material is too thick).	Choose a thinner workpiece material within the operational limits of the plasma cutting machine.
	There is moisture or oil in the air supply.	Excessive humidity or oil from the compressor may be contaminating the air supply. Install a moisture filter in the air supply line between the air compressor and the machine.
	Improperly assembled or loose PLASMA TORCH consumables.	Check all PLASMA TORCH consumables for proper installation.
	A damaged PLASMA TORCH consumable.	Check all PLASMA TORCH consumables for damage and replace if damaged.
	Non-genuine manufacturer's parts are being used.	Use only genuine Forney consumables for optimum performance.

Troubleshooting

PROBLEM	POSSIBLE CAUSE	POSSIBLE SOLUTION
	The thermal protector was engaged because the duty-cycle was exceeded.	Observe and maintain the proper duty-cycle while you allow the machine to cool for at least 10 minutes with the machine ON. The fault state will clear after the machine has cooled.
	Insufficient air flow caused the machine to overheat before reaching the duty cycle.	Check for obstructions blocking the airflow and ensure there are 12" of clearance between any obstacles and the vents on all sides of the machine.
	The torch triggered before the machine was powered on.	The MIG gun, TIG or plasma torch triggered or turned on before the machine was powered on. Simply release the gun trigger and the machine will reset within five seconds.
The fan is NOT operating and there is no output power.	There is no input power.	Connect the machine to the proper input power source. Verify the circuit breaker has not been tripped in your main power panel. Reset it if needed.
	The POWER SWITCH is OFF.	Ensure POWER SWITCH is in the ON position.
Frequent circuit breaker trips.	The machine is not the only piece of electrical equipment on the circuit.	Ensure the machine is on a dedicated circuit or is the only item plugged into a circuit.
	The circuit breaker is incorrect/insufficient for use with this machine.	Verify the circuit breaker is the correct one. See the "Machine Specifications" section of this manual.
The ground clamp or ground cable get hot.	The ground clamp is not properly placed or the ground clamp cable is not properly connected to the machine.	Check the connection of the ground clamp and gun to the machine.
		Check the connection of the ground cable to the ground clamp. Tighten the cable connection to the ground clamp if needed.
		Ensure the connection between the ground clamp and the workpiece is good and on clean, bare (not painted or rusted) metal.
		Ensure the cable is not damaged.

Machine Parts Diagram & Accessories

NO.	PART NUMBER	ITEM DESCRIPTION
1	357	Forney TruCut™
2	-	10' Ground Cable w/Clamp
3	-	Nylon Carry Strap
4	78040	15 to 20 Amp Plug Adapter

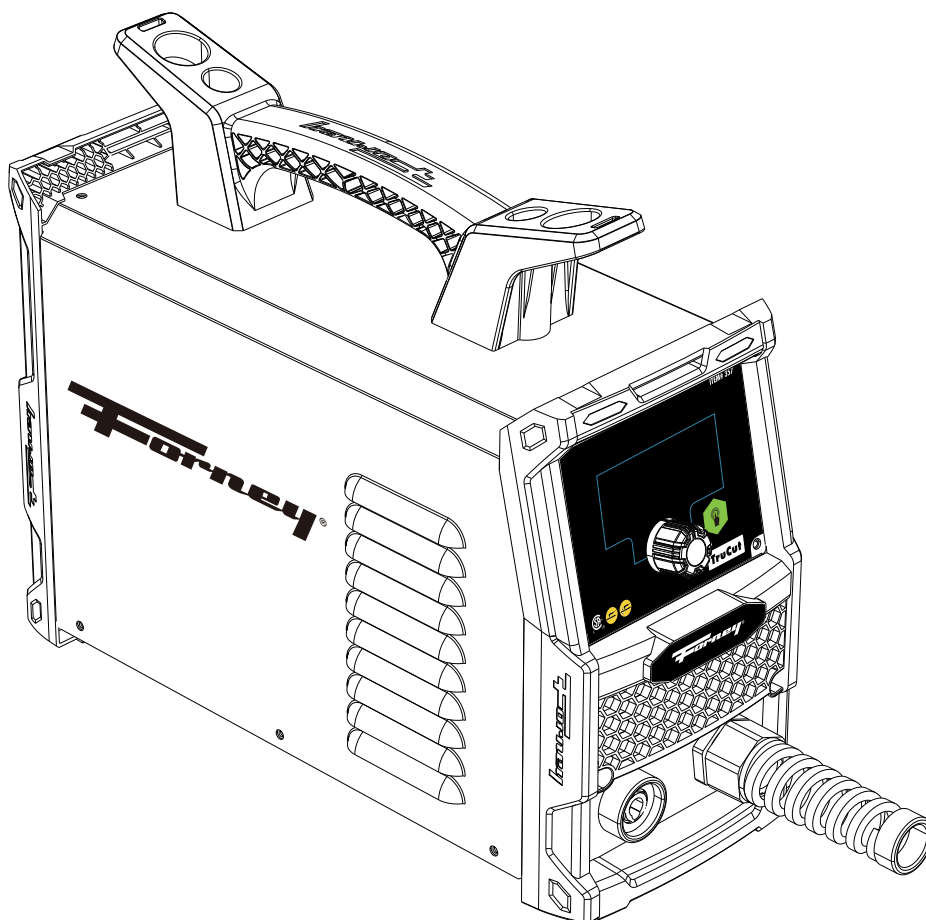

2



3

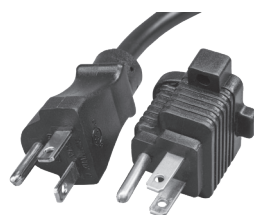

4

Plasma Consumables List - ITEM# 78011

NO.	PART NUMBER	ITEM DESCRIPTION	NO.	PART NUMBER	ITEM DESCRIPTION
1	85755 / 85392*	Electrode	2	85393	Air Diffuser Ring (Swirl Ring)
3	85414 / 85392*	Cutting Tip/Nozzle	4	85394	Shield Cup

**85392 is a 4-pack of consumables containing 2 electrodes and 2 cutting tips/nozzle.*

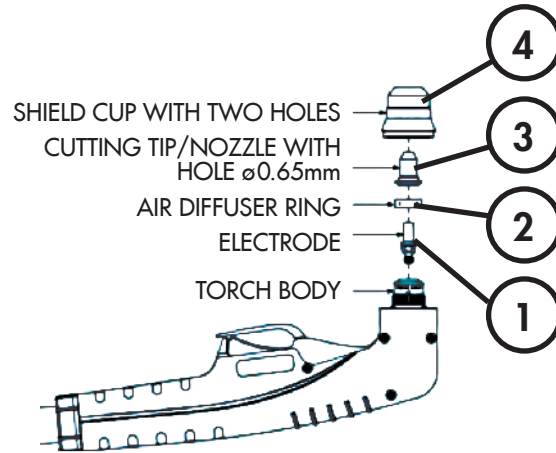



Forney Industries, Inc.
2057 Vermont Drive
Fort Collins, CO 80525
+1-800-521-6038
www.forneyind.com